



# GEO Semiconductor Inc.

**GW4100**

## NTSC/PAL Automotive Camera Processor

### General Description

The NTSC/PAL Automotive Camera Processor, GW4100, integrates GEO's patented Geometric processor eWARP® with an advanced High Dynamic Range (HDR) Image Signal Processor (ISP), On-screen Display engine (OSD), Parallel, MIPI, and NTSC/PAL interfaces. The device incorporates a Tensilica® Xtensa processor along with peripheral and serial device interfaces for complete system integration.

The eWARP® processor is GEO's fourth-generation version of the unique and highly patented geometric processor. The fully programmable geometric processor provides the flexibility and performance to correct complex lens distortion, enable electronic Pan/Tilt/Zoom, and manipulate viewing perspective in real time with sub-frame time latency. The eWARP® technology can create multiple detail views in a single pass generating a video stream with multiple virtual camera views. The eWARP® core also supports complex digital alignment and camera calibration.

The ISP provides High Dynamic Range (HDR) processing, spatial noise reduction, color processing, sharpening, and advanced 3A algorithms. The HDR technology applies different processing to each pixel of each video frame to pull out hidden detail in shadows and highlights while preserving color, local contrast, and natural appearance. The ISP supports HDR sensors that provide a dynamic range of up to 120dB revealing detail in both high-light and low-light areas of the scene simultaneously.

The On-screen Display (OSD) engine blends up to four layers of graphics with the video. The four layers can be a combination of both static and dynamic overlays. The static overlays enable text and logos while dynamic overlays are used for dynamic parking lines, active text, and animations. The OSD can support either RGB or YUV format.

### GW4100 NTSC/PAL Automotive Camera Processor

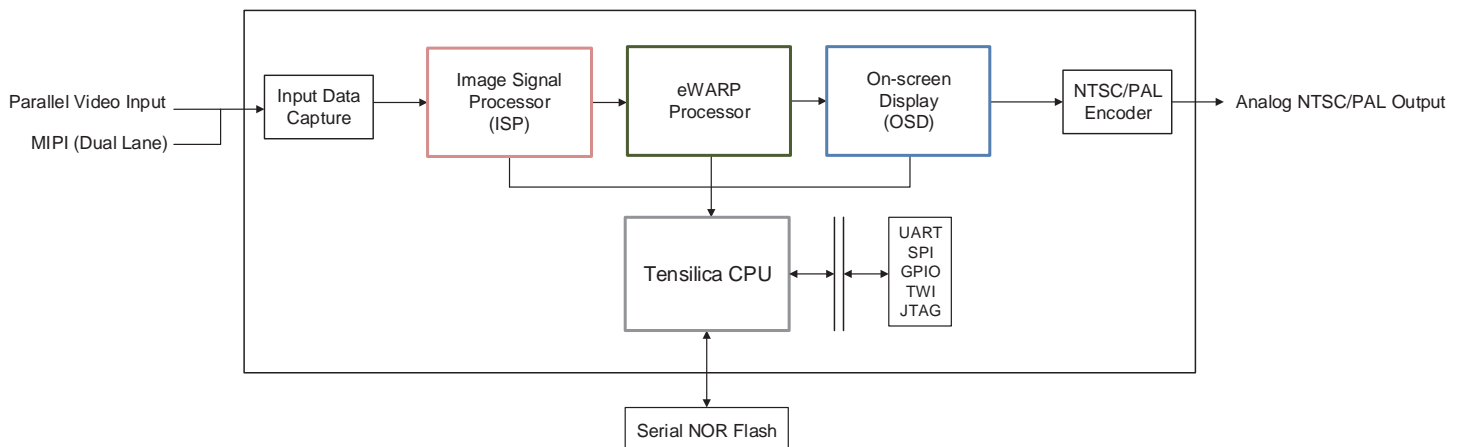



# GEO Semiconductor Inc.

## Features

### Camera Processor

- Ultra-wide field of view (FOV) lens distortion correction
- Dynamic Electronic Pan/Tilt/Zoom (ePTZ)
- Digital calibration for single and multiple camera systems
- Parallel geometric processing to generate multiple views in a single pass
- Full alignment, perspective correction, and blending for bird's eye view or surround view camera systems
- Very low latency mode (typically 1/6<sup>th</sup> of a frame)

### Advanced Geometric Processor

- GEO's proprietary eWARP<sup>®</sup> geometric processor
- Highly flexible programmable warp maps for distortion correction
- Real-time on-the-fly generation of warp maps
- Support for custom lens design

### Image Signal Processor

- Apical<sup>™</sup> ISP with 2MP, 1080p60 sensor support
- Space variant HDR processing
- HDR decompanding for high bit-depth image sensors
- Advanced spatial (2D) noise reduction
- Zone-based statistics for Auto White Balance and Auto Exposure
- Non-linear two-dimensional sharpening
- Dynamic defect correction
- Lens shading correction

### Applications

- Automotive rear view, front view, blind spot, mirror replacement, bird's-eye view, ADAS (Advanced Driver Assistance System), sensing, machine vision, and active safety cameras

### On-screen Display (OSD)

- Four layers of graphics, one static, three dynamic
- 256 colors selectable from 24 bpp true color range
- OSD overlay maximum resolution: 1920 x 1080
- Anti-aliasing support using color by color alpha
- Dynamic overlay support using animated static image
- Refresh rate: 30 fps for dynamic overlay update
- Lossless compressed bitmaps for high speed reads and reduced storage requirements

### Inputs/Outputs, Video Formats

- Input Interfaces: Dual lane MIPI and 12-bit Parallel
- Output Interfaces: Analog NTSC/PAL
- Input resolution up to 1920 x 1080 at 60fps
- Input Data Formats:
  - 8/10-bit YUV 4:2:2 over 8/10-bit interface
  - 8/10/12-bit Bayer RGB
- Output Data Formats:
  - Analog NTSC/PAL

### System Connectivity

- SPI Master, TWI Bus interfaces
- UART, JTAG, GPIOs, GPOs

### Electrical Specifications

- Power Supplies: 1.1V ±5%, 1.8V ±5%, 2.5V ±5%
- Typical power consumption: 262mW for 720p30
- Automotive Grade Operating Temp.: -40°C to 105°C AEC Q100 Grade2

### Ordering Information

Part Number	Package: Type, Pins	RoHS/Lead-Free
GW4100	109-pin TFBGA, 6mm x 6mm x 1.2mm, 0.5mm pitch	RoHS/Lead-Free

**World Headquarters**  
 GEO Semiconductor Inc.  
 101 Metro Drive, Suite 620  
 San Jose CA, 95110  
 Phone: (408) 638-0400

 **株式会社 エー・ディ・ティ**  
 (本社) 〒160-0011 東京都新宿区若葉 1-5-15 竹村ビル2F  
 TEL 03-5361-6680 FAX 03-5361-6683  
 (大阪営業所) 〒541-0059 大阪市中央区博労町 1-7-7 中央博労町ビル402  
 TEL 06-6267-8721 FAX 06-6267-8723  
**www.adt.co.jp E-mail: info@adt.co.jp**